

KRAUS KICKBACK ISOLATED RISERS FOR 1" AND 1-1/8" BAR

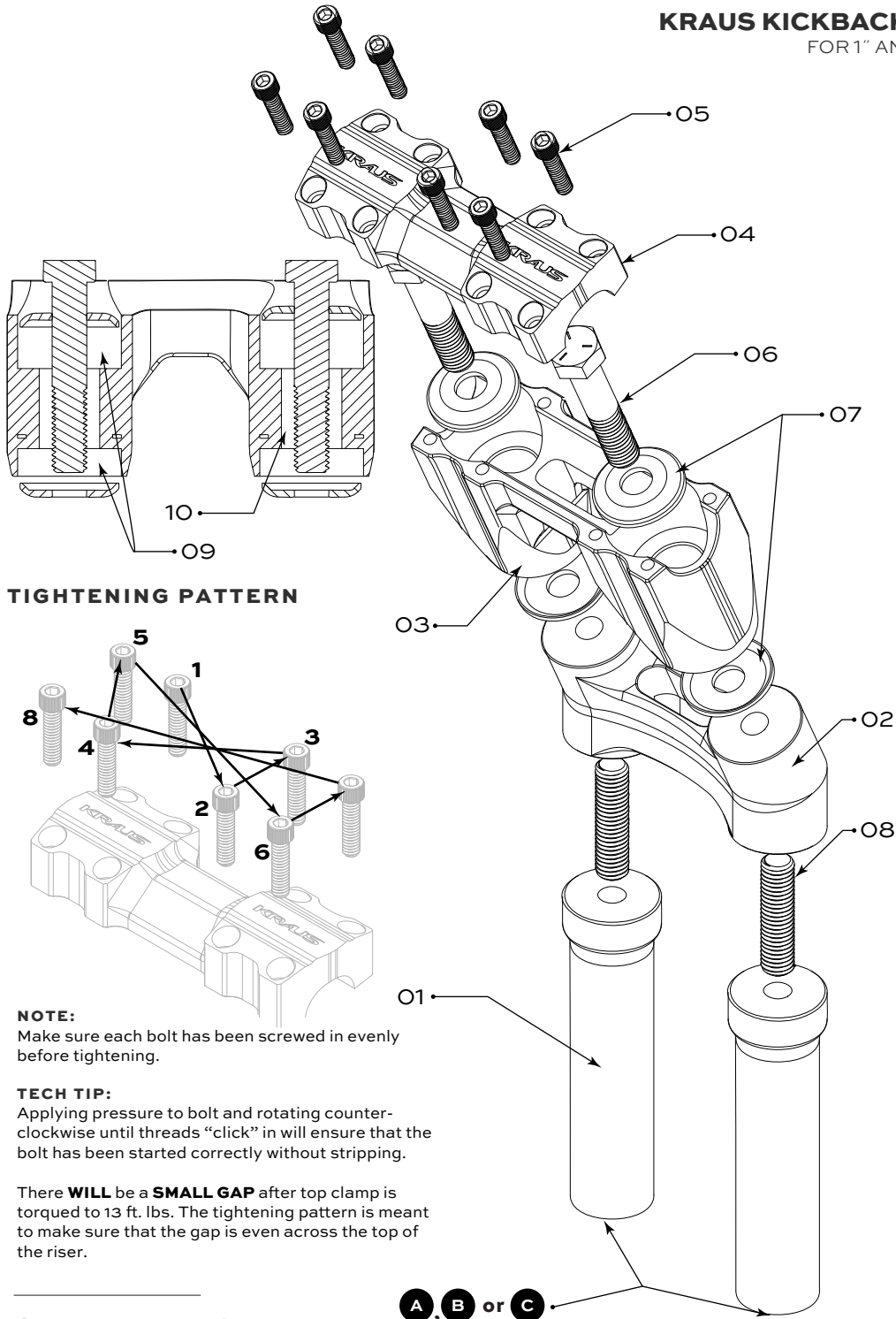

REPLACEMENT PART LIST:

ITEM	QTY	PART NO.	PART
1	2	UN-RI-35/45/75/95	ISO RISER LEGS 3.5", 5.5", 7.5", 9.5"
2	1	UN-ISO-004	ISOLATED RISER KICKBACK BRACE
3	1	UN-ISO-001/021	ISO RISER MID SECTION (1"/1-1/8")
4	1	UN-ISO-002/022	ISO RISER TOP CLAMP (1"/1-1/8")
5	8	1173462	18-8 STAINLESS STEEL SOCKET HEAD SCREW, 1/4-20 X 1
6	2	110120384	MEDIUM-STRENGTH GRADE 5 STEEL HEX HEAD SCREW, ZINC-PLATED, 1/2-13 X 2-1/2, PARTIALLY THREADED
7	4	UN-RI-014	RISER BUSHING WASHER - TOURING
8	2	32846	GRADE B7 MEDIUM-STRENGTH STEEL THREADED ROD, 1/2"-13 THREAD SIZE, 2" LONG
9	4 EA.	UN-RI-004	POLYURETHANE RISER BUSHING
10	2 EA.	UN-RI-004	METAL SLEEVE FOR POLY RISER BUSHING
A or B	2	13824	MEDIUM-STRENGTH GRADE 5 STEEL HEX HEAD SCREW, ZINC-PLATED, 1/2"-13 THREAD SIZE, 3" LONG, PARTIALLY THREADED
C	2	1113821	MEDIUM-STRENGTH GRADE 5 STEEL HEX HEAD SCREW, ZINC-PLATED, 1/2"-13 THREAD SIZE, 2" LONG, PARTIALLY THREADED

MOUNTING BUSHING SETS INCLUDED: (DEPENDS ON FITMENT)

FITMENT:

ALL TOURING MODELS AND 2018 & UP SOFTAILS

FITMENT:

ALL DYNA, FXR AND 2017 & BELOW SOFTAILS

FITMENT:

ALL MODELS RUNNING A KRAUS DYNAMOTO INVERTED FRONT END

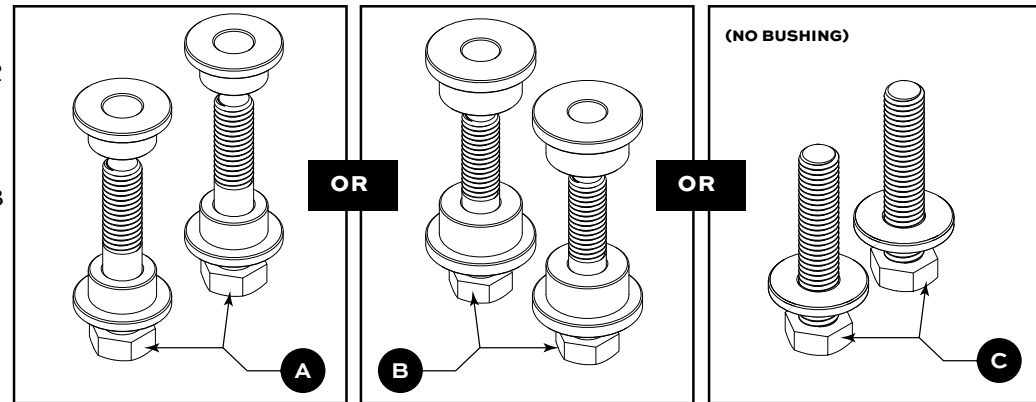

TORQUE SPECS:

- A** (SOLID MOUNT RISER BUSHING - TOURING/18 & UP SF) 1/2-13 X 2-1/2, GRADE 5 ZINC PLATED HEX HEAD SCREW — **55 FT. LBS.**
- B** (DYNA/FXR/17-BELOW SF SOLID RISER BUSHING) MEDIUM-STRENGTH GRADE 5 STEEL HEX HEAD SCREW ZINC-PLATED, 1/2-13 X 3 LONG, FULLY THREADED — **55 FT. LBS.**
- C** (KRAUS DYNAMOTO SOLID RISER BOLT & WASHER (NO BUSHING)) MEDIUM-STRENGTH GRADE 5 STEEL HEX HEAD SCREW ZINC-PLATED, 1/2-13 X 2 FULLY THREADED — **55 FT. LBS.**
- #05** 18-8 STAINLESS STEEL SOCKET HEAD SCREW, 1/4"-20 THREAD SIZE, 1" LONG — **13 FT. LBS.**
- #06** MEDIUM-STRENGTH GRADE 5 STEEL HEX HEAD SCREW, ZINC-PLATED, 1/2"-13 THREAD SIZE, 2-1/2" LONG, PARTIALLY THREADED — **55 FT. LBS.**

TIGHTENING PATTERN

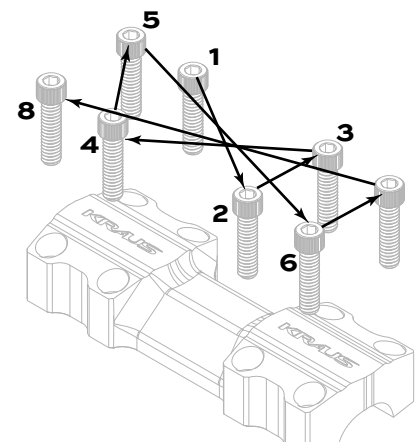

NOTE:
Make sure each bolt has been screwed in evenly before tightening.

TECH TIP:
Applying pressure to bolt and rotating counter-clockwise until threads "click" in will ensure that the bolt has been started correctly without stripping.

There **WILL** be a **SMALL GAP** after top clamp is torqued to 13 ft. lbs. The tightening pattern is meant to make sure that the gap is even across the top of the riser.