

PRO-LINE PERCH CLAMPS

PRODUCT GUIDE

TO BEGIN INSTALLATION...

- Remove the both bolts from OEM perch clamp
- NOTE:** Carefully support clutch and brake perch once the clamps have been removed to avoid damage.
- Begin to thread in the provide hardware through the Pro-Line Perch Clamps
- Install new perch clamps and find a suitable position for your hand controls, then tighten. **Torque to 6 ft-lbs (8 N-m)**

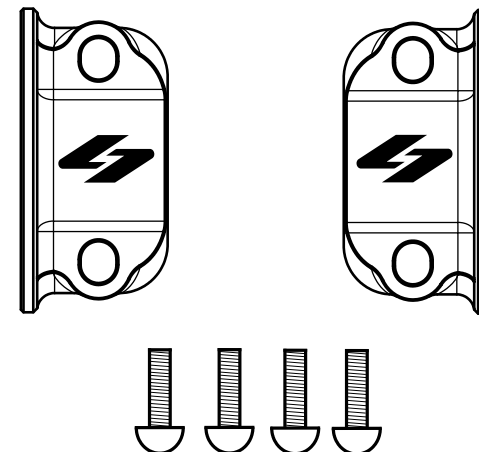

(Other items shown are sold separately)

