

Kit Contents		
Description	Part No	Pcs
Shock absorber	HD 505	1
Tie-rod	00231-01	5
Bracket	01082-11	1
Screw M6x30	05404-07	3
Nut	00430-02	3
Washer	00153-04	6
Sticker set Öhlins	10207-01	1
Owner's Manual Road & Track	07241-02	1

👁 Note!

Please note that there can be small differences between your product and the images in these instructions.

👁 Note!

Please note that during storage and transport, especially at high ambient temperature, some of the oil and grease used for assembly may leak and stain the packaging. This will not cause damage to the product, wipe off the excessive oil or grease with a cloth.

👁 Note!

Before you install this product, check the kit contents. If anything is missing, please contact an Öhlins dealer.

⚠ Warning!

Before you install this product, read the Öhlins Owner's manual. This product is an important part of the vehicle and the vehicle stability.

Shock absorber for Harley Davidson Softail

HD 505

Mounting Instructions

MOUNTING INSTRUCTIONS

⚠ Warning!

We strongly recommend to let an Öhlins dealer install this product.

⚠ Warning!

If you work with a lifted vehicle, make sure that it is safely supported to prevent it from tipping over.

👁 Note!

When you work with this product, see the vehicle service manual for vehicle specific procedures and important data.

👁 Note!

Before you install this product clean the vehicle.

1

Put the motorcycle on a work stand so that the rear wheel barely touches the ground.

2

Remove the lower attachment screws for the rear suspension.

3

Remove the front shock absorber attachment screw.

4

Remove the right side cover, then remove the standard hydraulic preload adjuster from the frame mount.

5

Remove the standard shock absorber, if necessary remove the frame bracket under the seat, above the suspension to gain more clearance.

6

Install the new shock by first pulling the preload adjuster and hose through the right side frame opening near the engine, from the seat side to the side cover side.

7

Let the preload adjuster hang freely; mount the shock absorber on to the frame.

Fat Bob Models (Figure 1)

8

Mount the preload adjuster bracket to the preload adjuster with loose tighten screws, mount the bracket to the frame (use the original screw and one new, see Fig 1.)

9

Mount the side cover and check for clearance, remove and adjust the preload adjuster bracket if not in a centered position.

Non-Fat Bob Models (Figure 2)

8

Mount the supplied preload adjuster bracket to outside of side cover, see Fig 2.)

9

Mount the side cover and check for clearance.

10

Fasten the hose with supplied cable ties. Make sure that the hose runs without sharp bends and that the hose is not squeezed when the rear suspension is compressed or extended.

11

Tighten all suspension shock screws with correct torque.

12

If necessary use the extra tie straps to keep the wire harness away from suspension shocks cylinder head.

MOUNTING INSTRUCTIONS

Fig. 1 - Standard mounting option for HD 505 (2018-22 Softail Fat Bob)

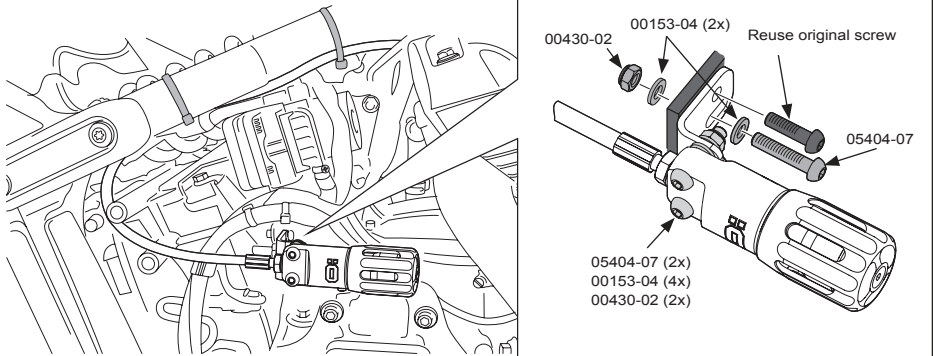
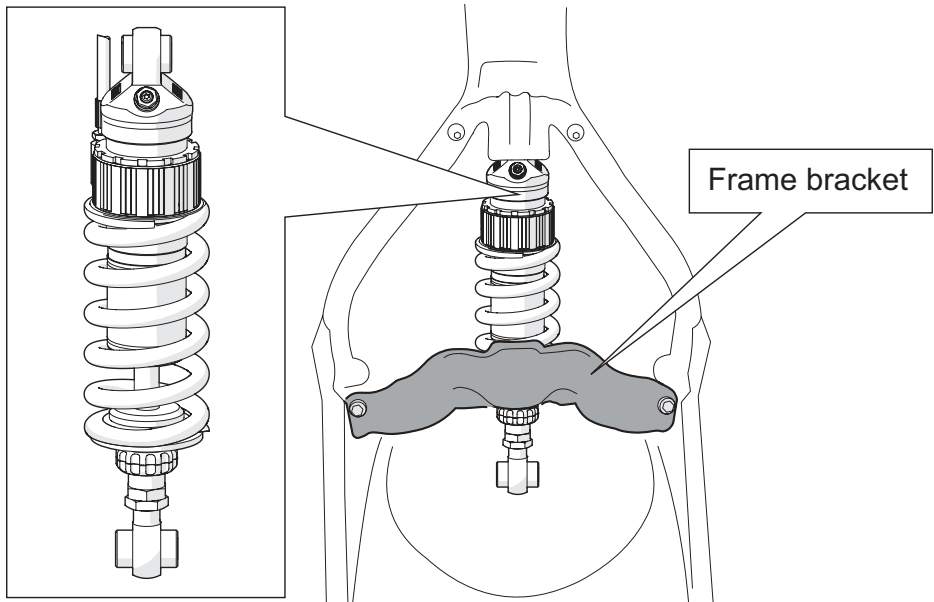
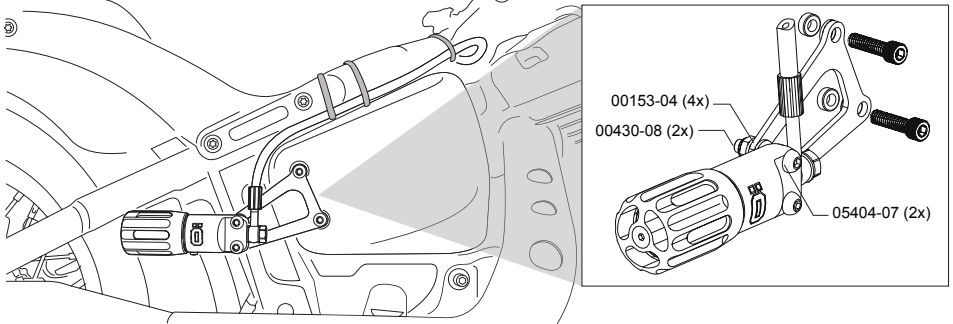

Fig. 2 - Mounting bracket option for HD 505LW (2018-22 Softail Lowrider, Deluxe, Slim, and Street Bob)



ADJUSTMENTS

⚠ Warning!

Before you ride/drive, always make sure that the setup is according to the recommended setup data. Read about adjustments and setting up in the Öhlins Owner's Manual before you make any adjustments. Contact an Öhlins dealer if you have any questions about setting up.

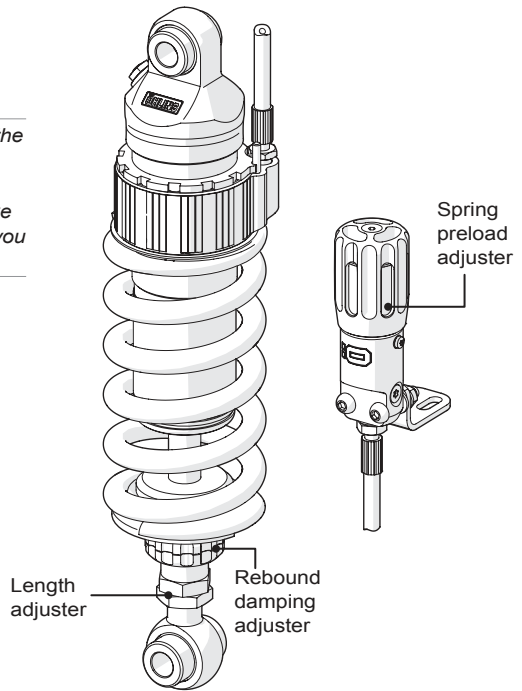

SETUP DATA

Length	330	mm
Length adjustment	+/- 6	mm
Stroke	43	mm
Rebound	16	clicks
Spring preload	19	mm
Spring rate	105	N/mm
Spring free length	170	mm
Spring	21102-36	

Recommended free sag and ride height		
R1-R2	7	mm
R1-R3	29	mm
F1-F2	18	mm
F1-F3	61	mm

Öhlins products are subject to continuous improvement and development, therefore, although these instructions include the most up-to-date information available at the time of printing, minor updates may occur.

To find the latest information contact an Öhlins distributor. Please contact Öhlins if you have any questions regarding the contents in this document.

Part no. MI_HD505_0
Issued 2019-02-21

© Öhlins Racing AB. All rights reserved. Any reprinting or unauthorized use without the written permission of Öhlins Racing AB is prohibited.

Öhlins Racing AB
Box 722
S-194 27 Upplands Väsby, Sweden
Phone +46 8 590 025 00
fax +46 8 590 025 80



www.ohlins.com