

Dynamoto INVERTED FRONT END PACKAGE. installation guide

SPORT PERFORMANCE INVERTED FRONT END PACKAGE FITMENT: Dyna, FXR, Sportster, Softtail

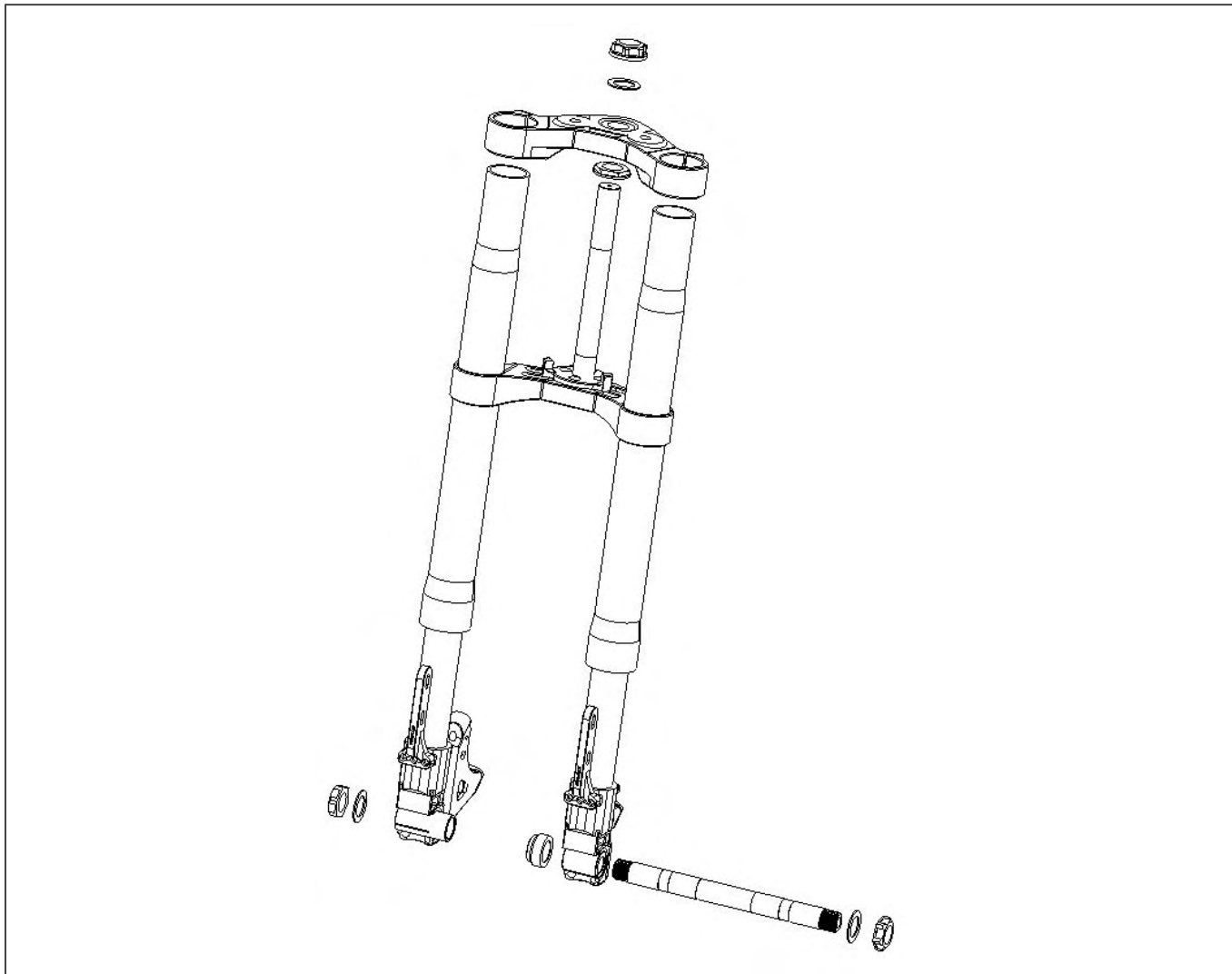

KRAUS Motor Company designs, engineers, and manufactures performance suspension and braking systems for Harley-Davidson™ motorcycles. These systems are designed to deliver improved handling and performance in diverse riding conditions.

These instructions are meant to be an overview, a guide for the experienced technician. If you do not have prior experience or training installing motorcycle suspension componentry, we strongly recommend that you consider hiring a qualified, experienced technician to install this KRAUS Performance package for you.

About Finishes:

Like most finishes, anodizing is delicate and can be scratched. Extra care should be taken during installation and cleaning of all anodized parts. Although we use a high grade type 2 anodizing that has UV resistance, anodizing is an organic process/ substance and can fade with excessive sun exposure and can be stained with certain chemicals and cleaners.

Dynamoto INVERTED FRONT END KIT installation guide

*Time Commitment: 1 full day for a Sr. Tech.
Existing Componentry and OEM Fork Set
Removal: 2 hours
KRAUS Performance Package install: 4 hours
Validation and Road Test: 1 hour*

Tools Required:

- *Torque wrench*
- *Allen Key Set: SAE & Metric*
- *Socket Set: SAE & Metric*
- *Flat Blade Screwdriver*

Begin at the point at which you have removed your OEM parts:

- Brakes
- Front Wheel
- Front forks
- Triple tree

And any associated bodywork or accessories.

Remember: take your time removing all of the controls and bodywork. We recommend covering your tank.

- 1**
Clean and re-pack your bike's neck bearings
- 2**
Install/slide the lower neck bearing dust shield followed by the lower neck bearing onto stem. Press them carefully onto the stem attached to the lower triple tree.
- 3**
Press the lower bearing down the stem towards the dust shield until firmly seated at the stem's base. The bearing should spin freely. **See Schematic 2.**
- 4**
Apply the specified and appropriate grease to the upper and lower neck bearing races.
- 5**
Carefully slide bottom triple tree and stem up through frame neck.
- 6**
Carefully place the top neck bearing onto the stem.
- 7**
Gently press the upper bearing down the stem towards the fork neck until firmly seated on the top bearing race. The bearing should spin freely. Place top dust shield over the top neck bearing.
- 8**
Apply a small amount of threadlocker **Blue** to The Kraus Triple Tree Tensioning Nut
- 9**
Tighten the Tensioning nut until snug then back off one flat so that the triple tree swings smoothly without excessive friction. Bearings should not have any play.
- 10**
Install bars and risers onto top triple tree.
- 11**
Install the top triple tree on top of Tensioning nut.
- 12**
Apply **Blue** threadlocker onto Yoke nut then install washer and Yoke nut, torque to **50 ft. lbs.**
- 13**
Ensure pinch bolts are loose. Starting with one side of the triple tree using small soft flat blade screwdrivers or shims, expand both top and bottom fork clamp pinch bolts slightly. Slide the fork into the triple trees, while avoiding marring the fork legs. Repeat process with opposite side.

Dynamoto INVERTED FRONT END KIT installation guide

14

Adjust the fork tube height in the triple trees so that just the fork cap is protruding above the top triple tree. Set both forks equal height in triple trees, confirm alignment by sliding the axle into the fork lowers.

15

Tighten the KRAUS **TOP** triple tree pinch bolts to **20 ft. lbs.** torque.

16

Tighten the KRAUS **BOTTOM** triple tree pinch bolts to **13 ft. lbs.** torque.

IMPORTANT!!!!!!

Once step 16 is complete check fall away before moving to step 17.

We recommending setting fall away to just a little tighter than stock.

17

Install Caliper Mounts onto fork lowers using supplied hardware. Use **Blue** threadlocker on bolt thread then torque to **7 ft lbs** Do Not tighten lower pinch bolts at this time.

18

If your model requires Kraus Rotor Spacers install between wheel hub and rotor. Use the supplied hardware. Depending on certain models hardware may remain stock. Use **Blue** threadlocker on bolt thread, tighten to OEM spec.

19

Prepare axle for install by lightly coating the surfaces of the axle with anti-seize or grease.

20

Slide the small Slit Fork Spacer into Left fork Lower with slit facing down, inline with fork pinch opening.

21

Slide Axle through left side of fork leg and into the KRAUS supplied left Stepped Wheel Bearing Spacer (small end of spacer facing the wheel bearing) or ABS sensor dependant on model. Through wheel hub and supplied Half Slit Right Wheel Bearing Spacer into the right fork lower. Align Slit facing down, inline with fork pinch opening with the unslit side of the spacer protruding inside of the fork towards the wheel.

22

Install supplied washers and axle nuts, apply **Blue** threadlocker to the axle threads and torque to **85 ft. lbs.**

23

Tighten axle nut set screws, to **3 in. lbs.** Using **Blue** threadlocker on set screw thread.

24

Lower bike onto wheel and bounce the front end to align the forks properly.

25

Tightening axle pinch bolts to **15 ft. lbs.**

Dynamoto INVERTED FRONT END KIT installation guide

26

Mount calipers onto the KRAUS Caliper Mounts using the supplied M10x1.25 bolts. Use **Blue** threadlocker on bolt thread, torque caliper bolts to **32 ft. lbs.**

27

Brake pads must be properly aligned and have full contact potential with rotor friction area. Add spacers between Radial calipers and mounts if needed.

28

Install Front Fender Mounts onto the fork lowers using supplied hardware. Use **Blue** threadlocker on bolt thread, torque to **132 in. lbs.**

29

Mount fender and torque the fender mounting bolts to **15 ft. lbs.** Use **Blue** threadlocker on bolt thread.

30

When re-installing your brake line, validate brake lines are proper length and not stressed or stretched whether the front end is compressed or extended.

31

Once the front end is installed and tightened up to specifications, you are ready to reinstall any bodywork or accessory componentry.

We recommend that you refer to your OEM manual for procedure, step by step run through, required tools and specifications.

All pieces and parts are properly installed! Go for a slow, careful test ride. Afterwards, double check all pieces, parts and systems.